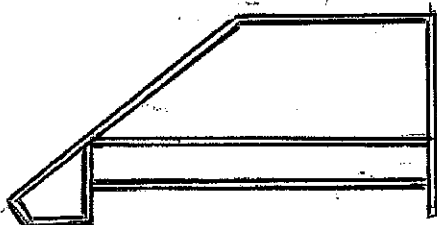
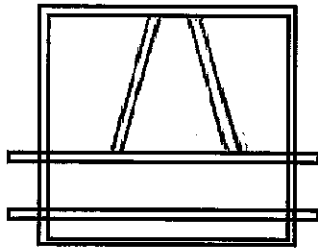

## 125cc Rotax Karting (Tar)

**The rule of what is not specifically allowed is not permitted; refer to WOMZA Tar Oval Technical Consultants for further clarity on the matter;**

**Competitor age restriction: Competitors over the age of 18 years old permitted only;**

RK 1. 1.1	<b><u>Chassis</u></b> Approved karting chassis and component's only, with manufacturer's serial number.
RK 2. 2.1 2.2 2.3 2.4	<b><u>Petrol Tanks</u></b> Must be firmly and adequately fixed to the chassis or the flooring; May not be a temporary system of attachment; The fuel tank must be constructed in such a way that neither it nor the fuel pipes, which must be flexible, present any danger of leakage during a competition; Pressurized tanks are prohibited;
RK 3 3.1 3.2 3.2.1	<b><u>Seat Belts</u></b> Must be a 4 point harness; All points of the harness must be secured on the chassis only; No harness may be secured in the roll cage;
RK 4 4.1 4.2	<b><u>Seats</u></b> Only kart manufactured seats are allowed (fiber glass) "Mini Balbi" Aluminium seats may be used.
RK 5 5.1 5.2 5.3	<b><u>Bumpers</u></b> Rear bumpers (steal or plastic) must cover the length of the rear wheels; Front plastic bumpers are optional to keep on or remove; No extra body kits are allowed;
RK 6 6.1 6.1.1 6.1.2	<b><u>Roll Cage</u></b> A 25mm steel round tubing must be used for the outer frame; 20mm or 25mm round tubing must be used for the support bars and inner struts; All roll cages must have the similar design ti the drawing below; Roll cages must be flexible to secure to turn and chassis to flex.   <b>SIDE</b>  <b>BACK</b>

WORLD OF MOTORSPORT  
womza@telkomsa.net

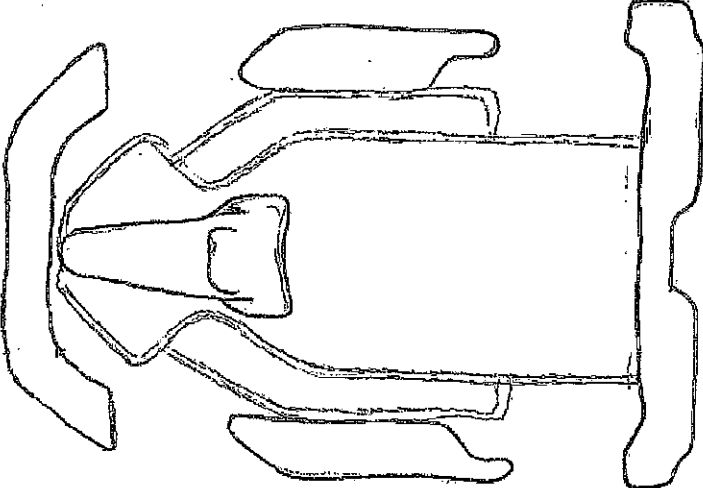
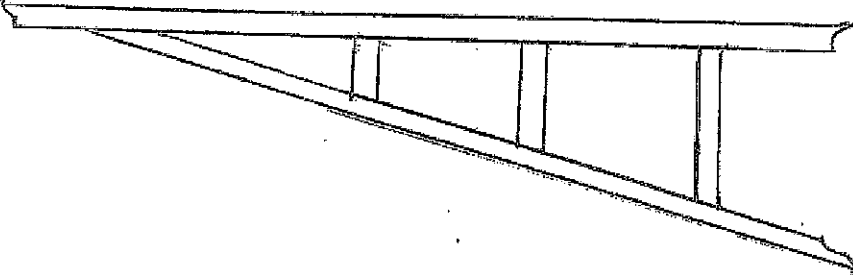
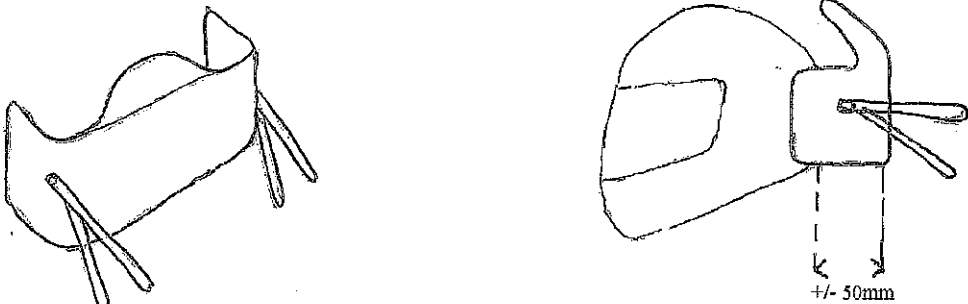
<p>RK 7 7.1 7.2</p>	<p><b>Sissy Bars or Side Pods</b> Plastic side pods or 20mm round tubing sissy bars may be used; Rear wheels must not protrude more than 10cm from the side bar/pods;</p> 
<p>RK 8 8.1 8.2</p>	<p><b>Safety Nets</b> Safety nets must be mounted on the right hand of the roll cage and driver; Safety net must cover the drivers head as shown in drawing below.</p> 
<p>RK 9 9.1 9.2 9.3 9.4</p>	<p><b>Head Support</b> Head support can be made out of aluminium and must cover and protect the head from the sides and back. Must have a foam lining to protect the helmet; Head support must be mounted at the back of roll cage not further than 50mm from the drivers helmet to support; Head support must be steady and tight as shown in drawing below.</p> 

## WORLD OF MOTORSPORT

womza@telkomsa.net

RK 10 10.1 10.2 10.2.1	<p><b>Numbers</b></p> <p>Numbers on the back bumper, front bib and the right side of the roll cage is compulsory; Size of the number on the front bib and back bumper may not be smaller than 15cm by 15cm; Size of the number on the side of the roll cage may not be smaller than 45cm by 25cm; All numbers on the kart must have large YELLOW background with a black number;</p>
RK 11. 11.1 11.2	<p><b>Chain and Sprocket</b></p> <p>A chain guard is compulsory and must efficiently cover the engine sprockets and the axle sprocket down a line; The chain must at least level with the center of both front and rear sprockets;</p>
RK 12. 12.1	<p><b>Weight</b></p> <p>There is no weight limit or restrictions on this class;</p>
RK 13 13.1	<p><b>Wings</b></p> <p>No wings will be allowed</p>
RK 14. 14.1 14.2 14.3 14.4 14.4.1 14.4.2 14.5 14.5.1	<p><b>Engine:</b></p> <p>FR 125 rotax senior max motor only; Engines, clutch, ignition, carburetor, airbox intake, silencer and exhaust pip will not be allowed to be modified; FR125 MAX engines are not to be modified in any way (see technical specifications of ROTAX engine type FR125 MAX); Each engine shall be sealed by an accredited Rotax Max Service Centre before being allowed to race; Only 'Authorized ROTAX Distributor's' and 'Authorized ROTAX Service Centers' are allowed to seal engines after carefully checking the engine according to the 'Technical Specification for the ROTAX FR 125 MAX engine'; Technical Specifications can be found be on the homepage <a href="http://www.maxchallenge-rotax.com">www.maxchallenge-rotax.com</a>; For all WOMZA events, special ROTAX seals (black anodized aluminum seal with "ROTAX" logo and a 6 digit number) with a steel cable must be used; At scrutineering the competitor has to present the engine with undamaged seal; Only engines sealed by the authorized distributor for ROTAX in Southern Africa or their appointed authorized service centers may be used at all events;</p>
RK 15. 15.1 15.1.2	<p><b>Carburetion</b></p> <p>Carburetion's must conform to the Technical Specifications of ROTAX engine type FR 125 MAX; To be found on the homepage <a href="http://www.maxchallenge-rotax.com">www.maxchallenge-rotax.com</a> and on <a href="http://www.kart.co.za">www.kart.co.za</a>;</p>
RK 16. 16.1	<p><b>Power Valve-Definition</b></p> <p>Any system which can alter by manual, electric, hydraulic or any other means, the normal exhaust port timing, or the actual flow of exhaust gasses at any point between the piston and the final exit of the exhaust when the engine is running is strictly forbidden;</p>
RK 17. 17.1	<p><b>Spark Plug</b></p> <p>Spark plugs permitted are "Denso IW" OR "NGK BR9/10EG</p>
RK 18. 18.1	<p><b>Clutch</b></p> <p>Clutch must be standard Rotax Senior Max;</p>

## WORLD OF MOTORSPORT

womza@telkomsa.net

RK 19. 19.1	<b>Helmets</b> Drivers helmets may not be higher than 5cm from the top of the roll cage when the driver is seated and secured
RK 20. 20.1 20.2	<b>Gearing/Transmission</b> The drive of the transmission shall always be to the rear wheels; The method and ratios (engine and sprockets) are free provided and no differential is incorporated;
RK 21. 21.1	<b>Tyres</b> Any brand of full slick karting and racing wet weather karting tyres are allowed;
RK 22. 22.1 22.2 22.3 22.4	<b>Brakes</b> Front brakes are optional; Back brakes are compulsory; "Floating discs" may be used; Every cart must have an extra cable for safety on brake arm from the pedal to the master cylinder
RK 23. 23.1 23.2 23.3	<b>Fuel Regulations</b> 95 Unleaded or 100 – 105 Afgas may be used; NOS is not permitted; NO racing fuel or mixtures are allowed to be used, 2 stroke Synthetic kart oil only
RK 24. 24.1	<b>Suspension</b> Any method of suspension e.g either by elastic material or by pivots is prohibited;
RK 25 25.1 25.2	<b>Pedals</b> Whatever the position of the pedals, they must not protrude , forward of the chassis, including the front bumper; Pedal operated and equipped with a return spring
RK 26 26.1 26.2	<b>Oil</b> Fully synthetic kart oil may be used; Any brand of synthetic oil for kart
RK 27 27.1 27.2	<b>Water / Antifreeze</b> Clean water or Kart antifreeze may be used; Only Anti-oil antifreeze may be used
RK 28 28.1 28.2 28.3	<b>Batteries</b> Any kart batteries may be used; Must be sealed than used of dry cell batteries; Batteries must be tightened and must have brackets.
RK 29. 29.1 29.2 29.3 29.4 29.5 29.6 29.7 28.8	<b>Race gear</b> Helmet Balaclava (Compulsory) Neck brace (Compulsory) Race suit (NO Kart suits) Level 1 and UP Gloves (Fire Proof) Race shoes only (Fire Proof) Rib Protector (Compulsory) Long Socks (Compulsory)